

# CPT tp conveyor with plastic belt

## TECHNICAL DATA SHEET

### DRIVE UNIT

- Position: pendular on the LH side
- Gear motor power: 0.18 kW
- Drive complete with torque limiter
- Conveyor speed: 4 m/min fixed
- Control: Siemens Start and Stop switch/motor cut-out
- Connection Voltage: 400 Volts/50 Hz
- Connection plug: 4P (3 phases+ground)

### PLASTIC BELT

- Covering: smooth RAL 9002 colour
- Modular Slats: h=35 mm, pitch=400 mm
- Temperature resistance: +1°C to +90°C
- Belt width: 275 to 575 mm (pitch 100 mm)

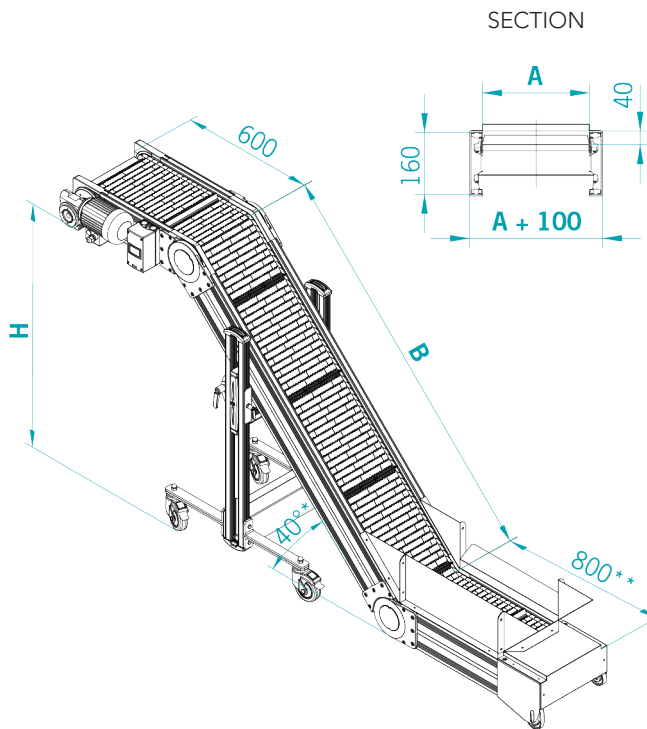

A (mm)	<input type="checkbox"/> 275	<input type="checkbox"/> 375
	<input type="checkbox"/> 475	<input type="checkbox"/> 575
B (mm)		
H (mm)		
Capacity (Kg)		
Material to be conveyed		
Specify presence of lubricant, coolant or other fluid, if present.		

\* inclination variable as per request (30° - 35° - 45°)  
 \*\* size variable on request

## OPTIONAL

### DRIVE UNIT

- Mounted on opposite side: RH side

### MB TOP CONTROL 400 Volt/3/50 Hz

- Mod. NEW TOP CONTROL complete with programs and with three-phase Inverter

### STANDARD FUNCTIONS

- Adjustable speed from \_\_\_\_\_ to \_\_\_\_\_ mt/min.
- Pause/Work for step-by-step advancement
- Robot/Pulse for timed advancement by external command

### LOADING HOPPER

- Loading hopper  
 L= \_\_\_\_\_ mm, H= \_\_\_\_\_ mm, P= \_\_\_\_\_ mm

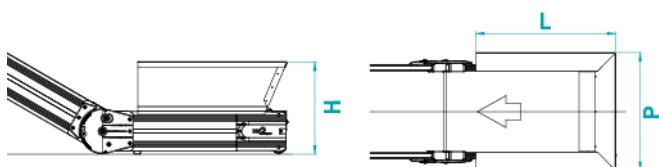

### UNLOADING CHUTE

- Standard unloading chute

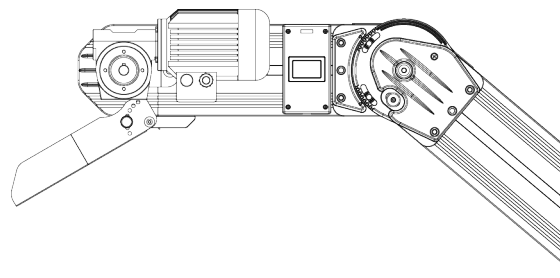

### NOTES