

N-TR conveyor

TECHNICAL DATA SHEET

DRIVE UNIT

- Position: pendular on the LH side
- Gear motor power: 0.12 kW
- Conveyor speed: 3 m/min fixed
- Control: Siemens Start and Stop switch/motor cut-out
- Connection Voltage: 400 Volts/50 Hz
- Connection plug: 4P (3 phases+ground)

BELT

- Smooth green PU covering (ref. Pantone 320)
- Vulcanised belt joint
- Temperature resistance: -10°C to +90°C

SECTION

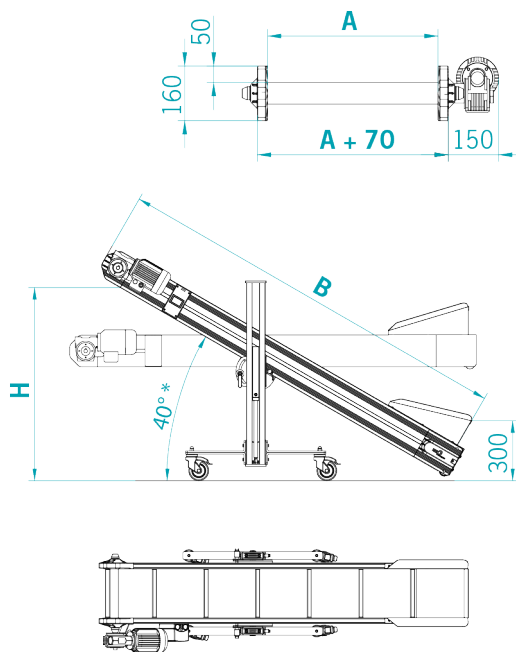

A (mm)	<input type="checkbox"/> 340	<input type="checkbox"/> 440
	<input type="checkbox"/> 540	

B (mm)	
--------	--

H a 40° (mm)	
--------------	--

Capacity (Kg)	
---------------	--

Material to be conveyed
Specify presence of lubricant, coolant or other fluid, if present.

* inclination variable as per request (30° - 35° - 45°)

OPTIONAL

DRIVE UNIT

- Mounted on opposite side: RH side

MB TOP CONTROL 400 Volt/3/50 Hz

- Mod. NEW TOP CONTROL complete with programs and with three-phase Inverter

STANDARD FUNCTIONS

- Adjustable speed from _____ to _____ mt/min.
- Pause/Work for step-by-step advancement
- Robot/Pulse for timed advancement by external command

UNLOADING CHUTE

- Standard unloading chute

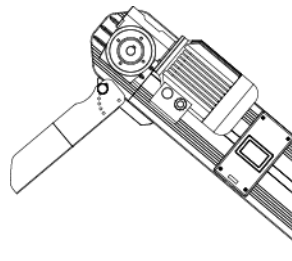

NOTES